

Чертеж

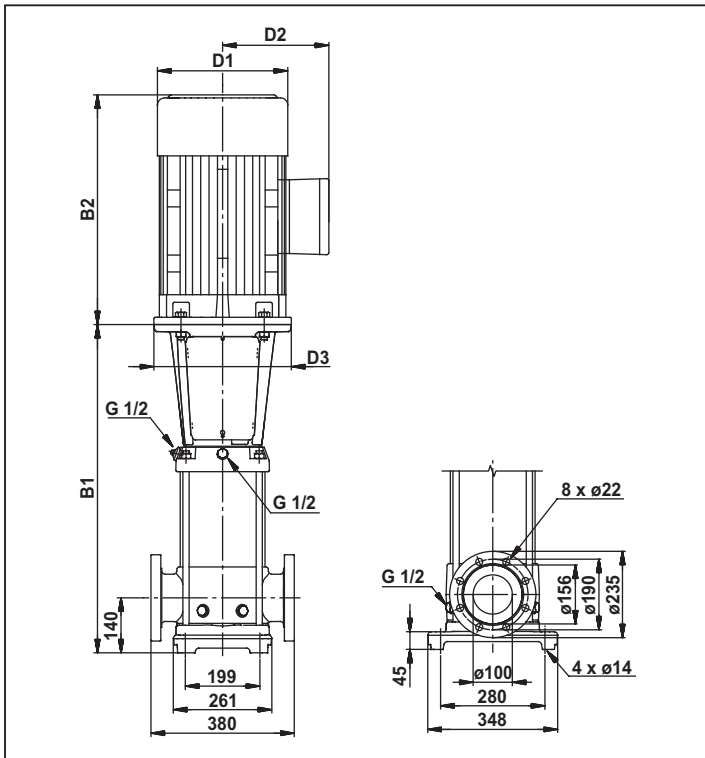

Размеры и вес

Модель	Размер в мм.					Вес (Кг)
	B1	B1+B2	D1	D2	D3	
SRN 90-1-1	571	962	220	134	350	118.0
SRN 90-1	571	962	220	134	350	122.0
SRN 90-2-2	773	1237	260	172	350	164.0
SRN 90-2	773	1251	306	197	350	197.0
SRN 90-3-2	865	1343	306	197	350	211.0
SRN 90-3	865	1425	364	269	350	264.0
SRN 90-4-2	957	1572	404	306	400	347.0
SRN 90-4	957	1572	404	306	400	347.0
SRN 90-5-2	1049	1664	404	306	400	372.0
SRN 90-5	1049	1664	404	306	400	372.0
SRN 90-6-2	1141	1791	459	342	450	437.0
SRN 90-6	1141	1791	459	342	450	437.0

Производительность

Модель	кВт.	Л. с.	Ампер	м³/ч л/мин	Глубина погружения (м.)							
					0	50	60	70	80	90	100	110
SRN 90-1-1	5.5	7.5	11		26	21	20	18	16	14	10	6
SRN 90-1	7.5	10	15.2		34	29	27	26	24	22	20	18
SRN 90-2-2	11	15	21.5		48	43	41	38	34	30	24	17
SRN 90-2	15	20	28.7		69	58	55	52	48	44	40	35
SRN 90-3-2	18.5	25	35.9		81	72	68	64	58	52	44	35
SRN 90-3	22	30	42		103	86	82	77	72	67	60	53
SRN 90-4-2	30	40	56		116	102	97	91	84	76	66	54
SRN 90-4	30	40	56		137	115	109	103	96	89	80	70
SRN 90-5-2	37	50	68		150	131	125	118	108	98	86	72
SRN 90-5	37	50	68		171	144	136	129	120	111	100	88
SRN 90-6-2	45	60	83		185	162	154	145	135	123	108	92
SRN 90-6	45	60	83		206	173	164	155	144	133	120	105

- ◆ Данные таблицы аппроксимированы в диаграмму.
- ◆ Возможны изменения технических характеристик.