

## Чертеж

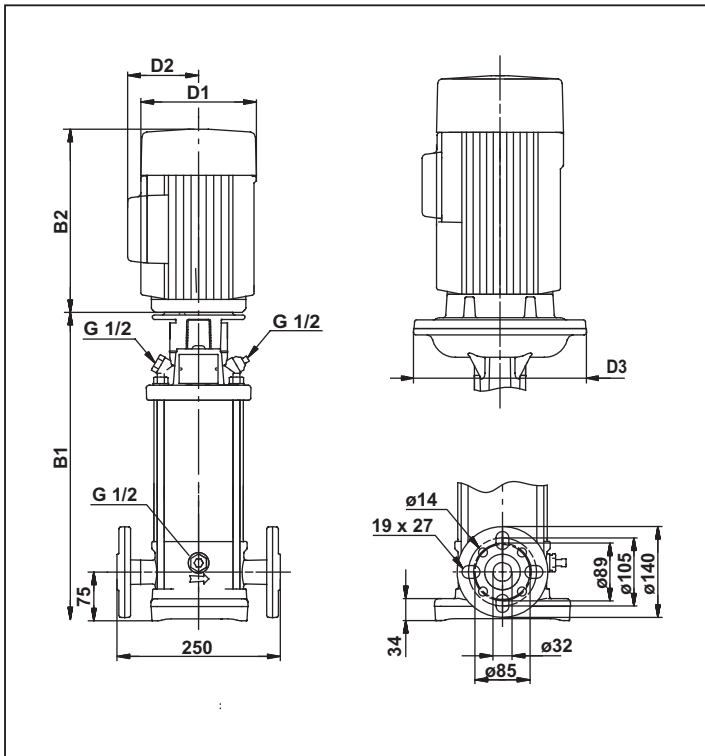

## Размеры и вес

Модель	Размер в мм.					Вес (Кг)
	B1	B1+B2	D1	D2	D3	
SRN 5-2	279	470	141	109	-	19.2
SRN 5-3	306	497	141	109	-	20.1
SRN 5-4	333	524	141	109	-	20.5
SRN 5-5	366	597	141	109	-	23.4
SRN 5-6	393	624	141	109	-	25.4
SRN 5-7	420	651	141	109	-	26.1
SRN 5-8	447	678	141	109	-	26.9
SRN 5-9	490	771	178	110	-	33.2
SRN 5-10	517	798	178	110	-	33.6
SRN 5-11	544	825	178	110	-	35.9
SRN 5-12	571	852	178	110	-	36.3
SRN 5-13	598	879	178	110	-	36.9
SRN 5-14	625	906	178	110	-	37.6
SRN 5-15	652	933	178	110	-	38.2
SRN 5-16	679	960	178	110	-	38.8
SRN 5-18	737	1072	198	120	-	45.6
SRN 5-20	791	1126	198	120	-	46.9
SRN 5-22	845	1217	120	134	-	56.6
SRN 5-24	899	1271	120	134	-	58.7
SRN 5-26	953	1325	120	134	-	60.0
SRN 5-29	1034	1406	120	134	-	61.9
SRN 5-32	1145	1536	120	134	300	76.7
SRN 5-36	1253	1644	120	134	300	79.3

## Производительность

Модель	кВт.	Л. с.	Ампер	м³/ч		0	2	3	4	5	6	7	8
				л/мин	0								
SRN 5-2	0.37	0.55	0.96	Глубина погружения (м.)	14	13	13	12	11	10	8	7	
SRN 5-3	0.55	0.75	1.44		20	20	19	18	16	14	12	10	
SRN 5-4	0.55	0.75	1.44		27	26	25	23	22	19	17	13	
SRN 5-5	0.75	1	1.86		34	33	31	29	27	24	21	17	
SRN 5-6	1.1	1.5	2.65		41	39	38	35	32	29	25	20	
SRN 5-7	1.1	1.5	2.65		47	46	44	41	38	34	29	23	
SRN 5-8	1.1	1.5	2.65		54	52	50	47	43	38	33	27	
SRN 5-9	1.5	2	3.4		61	59	56	53	49	43	37	30	
SRN 5-10	1.5	2	3.4		68	65	63	58	54	48	41	34	
SRN 5-11	2.2	3	4.75		74	72	69	64	59	53	46	37	
SRN 5-12	2.2	3	4.75		81	78	75	70	65	58	50	40	
SRN 5-13	2.2	3	4.75		88	85	81	76	70	62	54	44	
SRN 5-14	2.2	3	4.75		95	92	88	82	76	67	58	47	
SRN 5-15	2.2	3	4.75		101	98	94	88	81	72	62	50	
SRN 5-16	2.2	3	4.75		108	105	100	93	86	77	66	54	
SRN 5-18	3	4	6.4		122	118	113	105	97	86	75	60	
SRN 5-20	3	4	6.4		135	131	125	117	108	96	83	67	
SRN 5-22	3.7	5	8		149	144	138	128	119	106	91	74	
SRN 5-24	3.7	5	8	162	157	150	140	130	115	99	80		
SRN 5-26	3.7	5	8	176	170	163	152	140	125	108	87		
SRN 5-29	3.7	5	8	196	190	182	169	157	139	120	97		
SRN 5-32	5.5	7.5	11	216	209	200	187	173	154	132	107		
SRN 5-36	5.5	7.5	11	243	235	225	210	194	173	149	121		

- ◆ Данные таблицы аппроксимированы в диаграмму.
- ◆ Возможны изменения технических характеристик.