

Чертеж

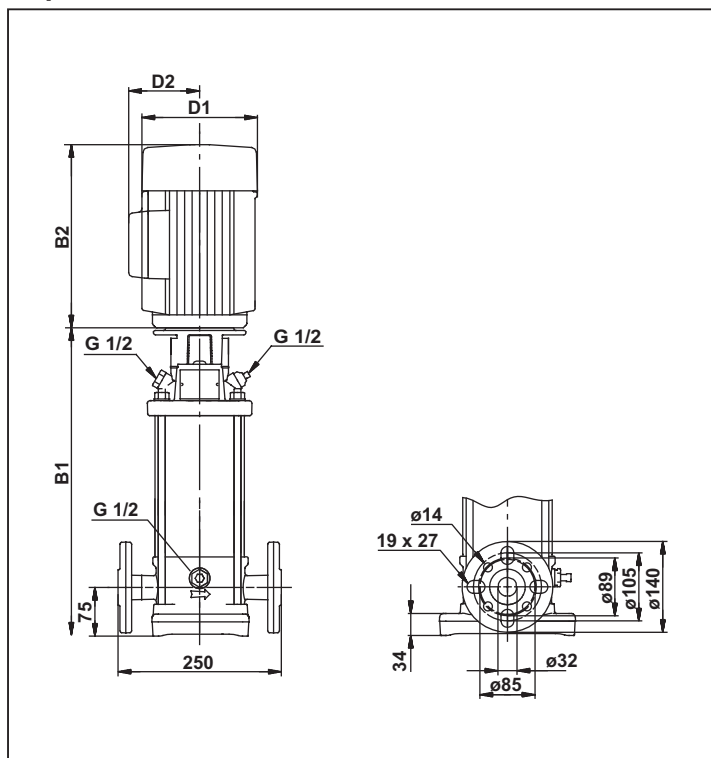

Размеры и вес

Модель	Размер в мм.					Вес (Кг)
	B1	B1+B2	D1	D2	D3	
SRN 1S-2	282	473	141	109	-	19.2
SRN 1S-3	282	473	141	109	-	19.2
SRN 1S-4	300	491	141	109	-	19.5
SRN 1S-5	318	509	141	109	-	19.8
SRN 1S-6	316	527	141	109	-	20
SRN 1S-7	354	545	141	109	-	20.6
SRN 1S-8	372	563	141	109	-	21.4
SRN 1S-9	390	581	141	109	-	21.8
SRN 1S-10	408	599	141	109	-	22.3
SRN 1S-11	426	617	141	109	-	22.8
SRN 1S-12	444	635	141	109	-	23.3
SRN 1S-13	462	653	141	109	-	23.6
SRN 1S-15	498	689	141	109	-	24.6
SRN 1S-17	534	725	141	109	-	25.1
SRN 1S-19	570	761	141	109	-	25.8
SRN 1S-21	612	843	141	109	-	28.3
SRN 1S-23	648	879	141	109	-	29.1
SRN 1S-25	684	915	141	109	-	30.3
SRN 1S-27	720	951	141	109	-	32.2
SRN 1S-30	784	1005	141	109	-	35.5
SRN 1S-33	828	1059	141	109	-	34.5
SRN 1S-36	882	1113	141	109	-	36.6

Производительность

Модель	кВт.	Л. с.	Ампер	м³/ч л/мин	Глубина погружения (м.)							
					0	0.4	0.5	0.6	0.7	0.8	0.9	1
SRN 1S-2	0.37	0.55	0.96	12	11	11	10	9	9	8	7	
SRN 1S-3	0.37	0.55	0.96	17	17	16	15	14	13	12	11	
SRN 1S-4	0.37	0.55	0.96	23	22	21	20	19	17	16	14	
SRN 1S-5	0.37	0.55	0.96	29	28	27	25	24	22	20	18	
SRN 1S-6	0.37	0.55	0.96	35	33	32	30	28	26	24	22	
SRN 1S-7	0.37	0.55	0.96	41	39	37	35	33	31	28	25	
SRN 1S-8	0.37	0.55	0.96	46	44	42	40	38	35	32	29	
SRN 1S-9	0.37	0.55	0.96	52	50	48	45	42	39	36	32	
SRN 1S-10	0.37	0.55	0.96	58	55	53	50	47	44	40	36	
SRN 1S-11	0.37	0.55	0.96	64	61	58	55	52	48	44	39	
SRN 1S-12	0.37	0.55	0.96	70	66	64	60	57	52	48	43	
SRN 1S-13	0.37	0.55	0.96	75	72	69	65	61	57	52	47	
SRN 1S-15	0.55	0.75	1.44	87	83	80	75	71	66	60	54	
SRN 1S-17	0.55	0.75	1.44	99	94	90	85	80	74	68	61	
SRN 1S-19	0.55	0.75	1.44	110	105	101	95	89	83	76	68	
SRN 1S-21	0.75	1	1.86	122	116	111	105	99	92	84	75	
SRN 1S-23	0.75	1	1.86	133	127	122	115	108	101	92	83	
SRN 1S-25	0.75	1	1.86	145	138	133	126	118	109	100	90	
SRN 1S-27	1.1	1.5	2.65	157	149	143	136	127	118	108	97	
SRN 1S-30	1.1	1.5	2.65	174	166	159	151	141	131	120	108	
SRN 1S-33	1.1	1.5	2.65	191	182	175	166	155	144	132	118	
SRN 1S-36	1.1	1.5	2.65	209	199	191	181	170	157	144	129	

- ◆ Данные таблицы аппроксимированы в диаграмму.
- ◆ Возможны изменения технических характеристик.

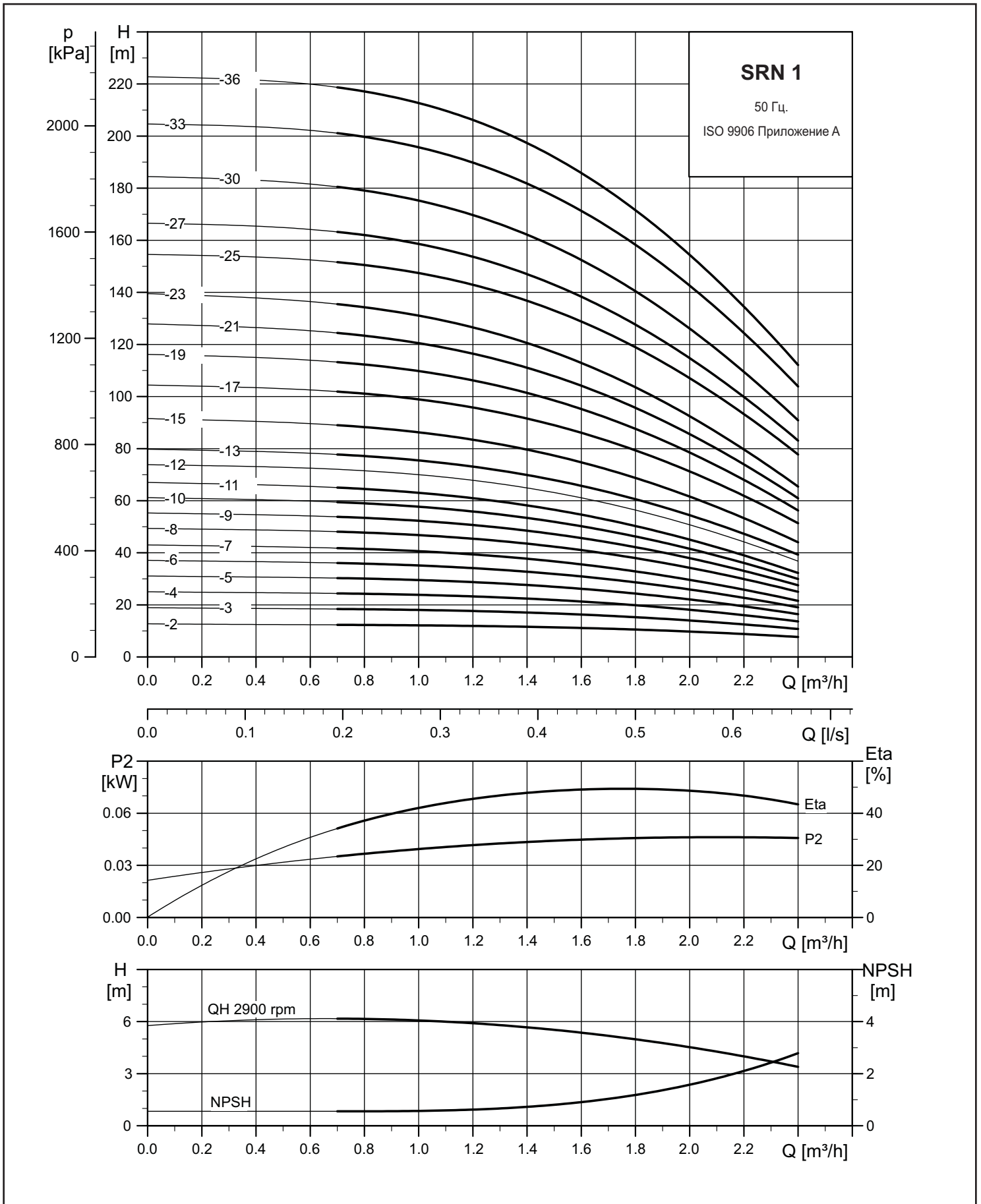

Чертеж

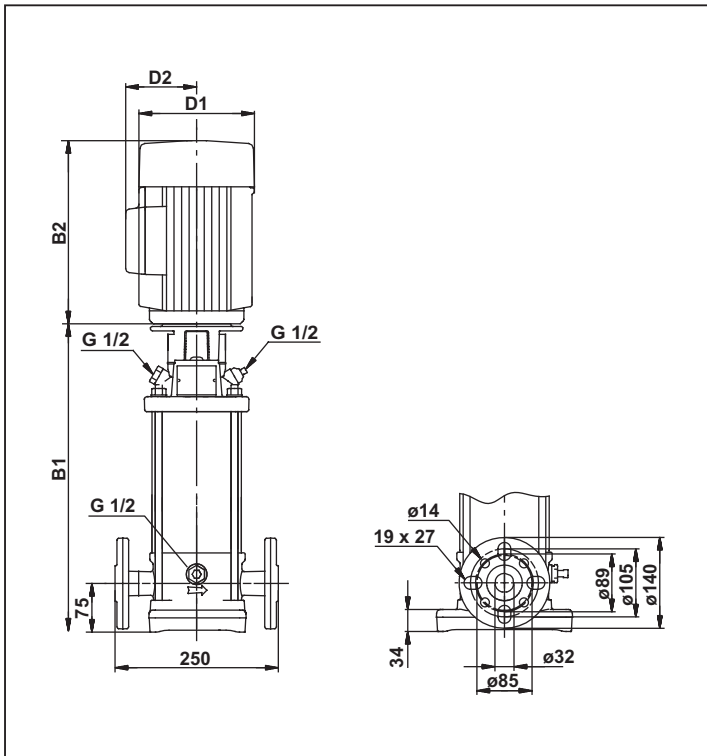

Размеры и вес

Модель	Размер в мм.					Вес (Кг)
	B1	B1+B2	D1	D2	D3	
SRN 1-2	279	470	141	109	-	19.2
SRN 1-3	279	470	141	109	-	19.2
SRN 1-4	297	488	141	109	-	19.5
SRN 1-5	315	506	141	109	-	19.8
SRN 1-6	333	524	141	109	-	20.0
SRN 1-7	351	542	141	109	-	20.6
SRN 1-8	369	560	141	109	-	21.9
SRN 1-9	387	578	141	109	-	23.3
SRN 1-10	405	596	141	109	-	22.8
SRN 1-11	423	614	141	109	-	23.3
SRN 1-12	447	678	141	109	-	25.5
SRN 1-13	465	696	141	109	-	25.7
SRN 1-15	501	732	141	109	-	26.3
SRN 1-17	537	768	141	109	-	28.2
SRN 1-19	573	804	141	109	-	28.9
SRN 1-21	609	840	141	109	-	29.7
SRN 1-23	645	876	141	109	-	30.5
SRN 1-25	697	978	178	110	-	37.6
SRN 1-27	733	1014	178	110	-	38.1
SRN 1-30	787	1068	178	110	-	39.4
SRN 1-33	841	1122	178	110	-	42.4
SRN 1-36	895	1176	178	110	-	44.5

Производительность

Модель	кВт.	Л. с.	Ампер	м ³ /ч л/мин	0	0.8	1	1.2	1.4	1.6	1.8	2
					0	13	17	20	23	27	30	33
SRN 1-2	0.37	0.55	0.96	Глубина погружения (м.)	12	12	12	11	11	10	9	8
SRN 1-3	0.37	0.55	0.96		19	18	17	17	16	15	14	12
SRN 1-4	0.37	0.55	0.96		25	24	23	22	21	20	19	17
SRN 1-5	0.37	0.55	0.96		31	30	29	28	27	25	23	21
SRN 1-6	0.37	0.55	0.96		37	35	35	34	32	30	28	25
SRN 1-7	0.37	0.55	0.96		43	41	40	39	37	35	32	29
SRN 1-8	0.55	0.75	1.44		50	47	46	45	43	40	37	33
SRN 1-9	0.55	0.75	1.44		56	53	52	50	48	45	42	37
SRN 1-10	0.55	0.75	1.44		62	59	58	56	53	50	46	41
SRN 1-11	0.55	0.75	1.44		68	65	63	61	59	55	51	46
SRN 1-12	0.75	1	1.86		74	71	69	67	64	60	56	50
SRN 1-13	0.75	1	1.86		81	77	75	73	69	65	60	54
SRN 1-15	0.75	1	1.86		93	89	87	84	80	75	69	62
SRN 1-17	1.1	1.5	2.65		105	100	98	95	91	85	79	70
SRN 1-19	1.1	1.5	2.65		118	112	110	106	101	95	88	79
SRN 1-21	1.1	1.5	2.65		130	124	121	117	112	105	97	87
SRN 1-23	1.1	1.5	2.65		143	136	133	129	123	115	106	95
SRN 1-25	1.5	2	3.4		155	148	144	140	134	126	116	104
SRN 1-27	1.5	2	3.4		167	159	156	151	144	136	125	112
SRN 1-30	1.5	2	3.4		186	177	173	168	160	151	139	124
SRN 1-33	2.2	3	4.75	205	195	190	184	176	166	153	137	
SRN 1-36	2.2	3	4.75	223	212	208	201	192	181	167	149	

- ◆ Данные таблицы аппроксимированы в диаграмму.
- ◆ Возможны изменения технических характеристик.